

<b>Product</b>	<b>nSens-HT-EIM</b>	<b>novasina</b> The Art of Precision Measurement
<b>Document</b>	Technical data sheet	Novasina AG CH-8853 Lachen
<b>Doc No&amp;Index</b>	007179.01	Page 1 / 2

**nSens-HT-EIM:  
Electrolytic high precision humidity measurement in metal housing (stainless steel) for installation in incubators, cleanrooms, food production areas etc**



Digital humidity / temperature sensor based on electrolytic-resistive measurement technology. In stainless steel body and 5 meter bus cable.

Ideal for all applications that requires high precision, fast response time and long term stability. Ideal also for high humidity environment and elevated temperatures.

Communication based on nSens-Bustechnology. Sensor is compatible with all nSens components (cables, transmitters, handhelds etc)

Delivery inclusive 5 metre nSens cable (3 wire)

**Art. Nr. 260 1993 (nSens-HT-EIM)**

**Technical data**

Description	nSens-HT-EIM Electrolytic humidity and NTC temperature measurement		
Measuring range	Humidity	0 ... 100% rH	
	Temperature	-20 ... +80°C	
Accuracy incl. reproducibility and hystereses	Humidity*	15 ... 30°C	<b>typical +/- 0.4% rH</b>
		0 ... 50°C	<b>typical +/- 0.8% rH</b>
		-20 ... 80°C	<b>typical +/- 1.2% rH</b>
	Temperature	0 ... +65°C -20 ... +80°C	typical +/- 0.1K typical +/- 0.2K
Drift	Humidity	typical <1%/ year	
Calibration Points	Humidity	13 points complete measuring range	
	Temperature	2 points complete measuring range	
Communication	digital (nBus Bussystem)		
Housing material	Stainless Steel (body)		
Mechanical protection	Outside SS mesh filter, inside nCap-PS Silveroxyd filter		
Operating temperature	-20 to +80°C		
Storing temperature	0 to +60° C (non condensing)		
Chemical durability	Sensor and housing durable against H <sub>2</sub> O <sub>2</sub> , NH <sub>3</sub> up to 1%.		

\* The humidity accuracy refers to the nominal values of Novasina humidity standards, which refer to the Greenspan Report.

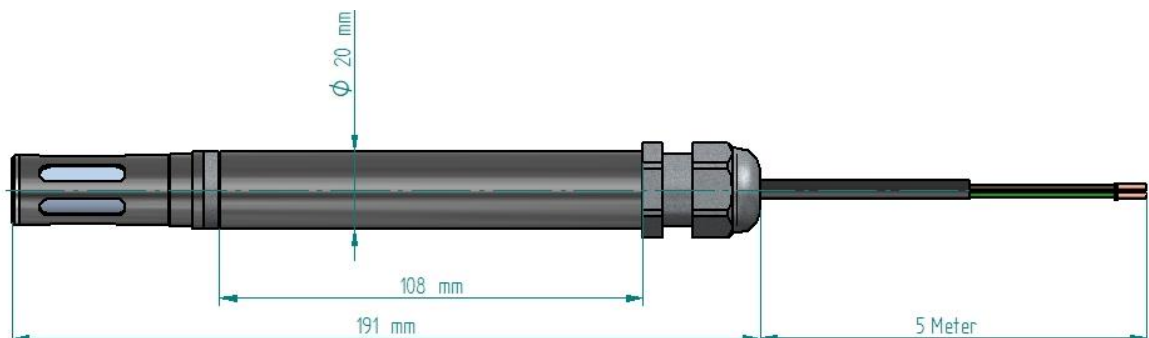

<b>Product</b>	<b>nSens-HT-EIM</b>	<b>novasina</b> The Art of Precision Measurement
<b>Document</b>	Technical data sheet	Novasina AG CH-8853 Lachen
<b>Doc No&amp;Index</b>	007179.01	Page 2 / 2

### Connectivity options / required accessories:

#### Transmitters for process automation and monitoring systems

nLink+ IP AS	2 Analog Signal Output 0/4 - 20mA or 0/2-10V	IP65 protection
nLink+ EC AS	2 Analog Signal Output 0/4 - 20mA or 0/2-10V	Electrical cabinet installation
Quantadat	4 Analog Signal Output 0/4 - 20mA or 0/2-10V	IP54 LCD Display
nLink+ IP MR	Digital Modbus RTU / RS485	IP65
nlink-USB Smart	USB-A&C Connection for Smartphones or PC	Android App for measurement and logging PC software nSoft CAL pro for measurement and logging

#### Windows PC and Android calibration options

nSoft-Cal	PC Software for single nSens calibration	Requires USB cable <b>nlink-USB</b>
nSoft-Cal PRO	PC Software for <b>multi sensor calibration</b> and logging	Requires USB cable <b>nlink-USB-SMART</b>
nSens Mobile	Android App for measurement and calibration	Requires USB cable <b>nlink-USB-SMART</b>

nSoft-Cal&nSoft-Cal-Pro software available for download on [www.novasina.ch/climate](http://www.novasina.ch/climate)  
Android App available on Google Play Store