

# nLINK+ AS

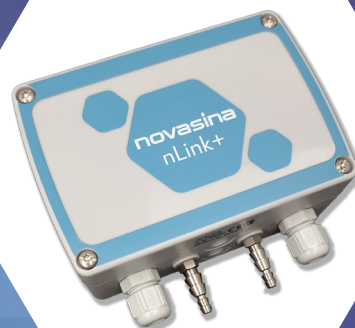

# MANUAL

Novasina AG  
Neuheimstrasse 12  
CH-8853 Lachen  
Tel:+41 55 642 67 67  
sales@novasina.ch

## TABLE OF CONTENTS

<b>1.</b>	<b>SCOPE OF APPLICATION</b>	<b>3</b>
<b>2.</b>	<b>GENERAL</b>	<b>3</b>
<b>3.</b>	<b>SAFETY</b>	<b>3</b>
<b>4.</b>	<b>PRODUCT DESCRIPTION</b>	<b>4</b>
4.1	TECHNICAL DATA nLINK+ IP AS	4
4.2	TECHNICAL DATA nLINK+ DI AS	5
4.3	TECHNICAL DATA nLINK+ EC AS	6
4.4	TECHNICAL DATA nLINK+ IP AS DP	7
4.5	TECHNICAL DATA nLINK+ DI AS DP	8
4.6	TECHNICAL DATA nLINK+ EC AS DP	9
4.7	WIRING DIAGRAM	10
4.8	ELECTRICAL INSTALLATION	10
4.9	TUBE CONNECTIONS	10
<b>5.</b>	<b>INITIAL OPERATION</b>	<b>11</b>
5.1	DISPLAY FUNCTIONS	11
<b>6.</b>	<b>WINDOWS PC SOFTWARE INSTALLATION</b>	<b>12</b>
<b>7.</b>	<b>CONFIGURATION WITH nSOFT-ACT-T</b>	<b>12</b>
7.1	STARTUP	12
7.2	MAIN SCREEN	13
7.3	CONFIGURATION PROCEDURE	14
7.4	UPDATE REQUIRED	14
7.5	NEW CONFIGURATION	14
7.6	CONFIGURATION ANALOG OUTPUTS	15
7.7	MANUAL VALUES	16
7.8	SENSOR CALIBRATION	16
<b>8.</b>	<b>CALIBRATION / VERIFICATION OF MEASURING VALUES</b>	<b>17</b>
8.1	SENSOR CABLES AND CONFIGURATION SET	17
8.2	ACCESSORIES nSENS HT	18

## 1. SCOPE OF APPLICATION

This manual is valid for all nLink+ transmitter systems with firmware version V01.00 or higher.

## 2. GENERAL

The nLink+ Transmitter has been designed for fixed mounting, either directly at or near the measuring location (IP version) or in the electrical cabinet (EC version=electrical cabinet).

All nSens probes are compatible, either directly on the housing (IP version) or by the 3wire nSens cable or the nSens extension cable.

Configuration possible with the built in USB connection by Windows PC.

## 3. SAFETY

This instrument has left the factory in a faultless condition. No inappropriate modifications are allowed under the terms or the warranty. Please consider all notices and warning signs on the instrument and in this operating manual.

Please also note:

- This instrument has been developed only for the measurement of clean air within the defined specifications, operate the instrument only for this purpose. In case of other applications, outside of these specified uses, the supplier accepts no responsibility for any damage caused.
- The installation work shall be only done by skilled personnel (electrician).
- The instrument may only be operated under the specified operating conditions.
- Any faults that may occur and cause damage to material and people, additional safety precautions should be implemented. In case of any faults, the defined operating conditions have to be observed (e.g. limit switch etc.).
- The instrument is not adequate for the installation in rooms with explosion hazard.
- The installation has to be effected in accordance with the local electrical installation regulations as well as this operating manual.
- The instrument contains ESD-sensitive parts. Please follow the indicated safety measures.
- Use only original Novasina accessories and spare parts.
- Without any written approval by Novasina no adaptations and modifications shall be undertaken on the instrument

## 4. PRODUCT DESCRIPTION

### 4.1 TECHNICAL DATA NLINK+ IP AS

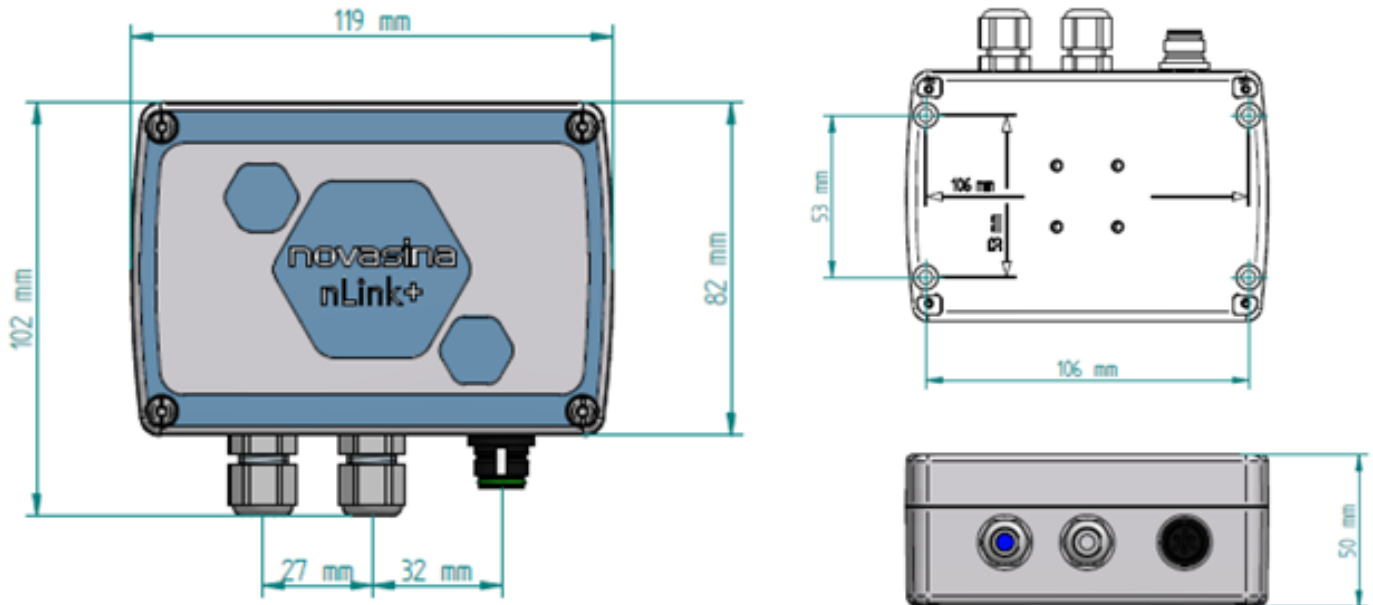

<b>Name</b>	nLink+ IP AS
<b>Art.-Nr.</b>	2602078
<b>Power supply</b>	24V DC, Permissible voltage range: 5 to 39V
<b>Power consumption</b>	<0.5W
<b>Status LED</b>	LED for power On, LED for nSens connected
<b>Output</b>	2 scalable analog outputs, current 0/4..20mA or voltage 0/2..10V  Accuracy <0.05% of span Linearity <0.05% of span Temperature effect 0.005% of span / °C  Load (I): min. 0Ω / max. 500Ω or (Uin-2V)/Imax Load resistance (U): min. 10 kΩ / max. ∞Ω
<b>Housing material</b>	PC/ABS
<b>Protection class</b>	IP65
<b>Soldering material</b>	lead free (RoHS compliant)
<b>Working temp.</b>	0 to 50°C
<b>Storage temperature</b>	-10 to 60°C (non-condensing)
<b>Compatibility</b>	Compatible with all nSens-HT V2.14 and later or nSens-dp
<b>CE-/EMC</b>	Safety: IEC 61010-1:2020 EMC: IEC 61000-6-2:2016, EN 61000-6-2:2019 IEC 61000-6-3:2020, EN 61000-6-3:2007+A1:2011

## 4.2 TECHNICAL DATA NLINK+ DI AS

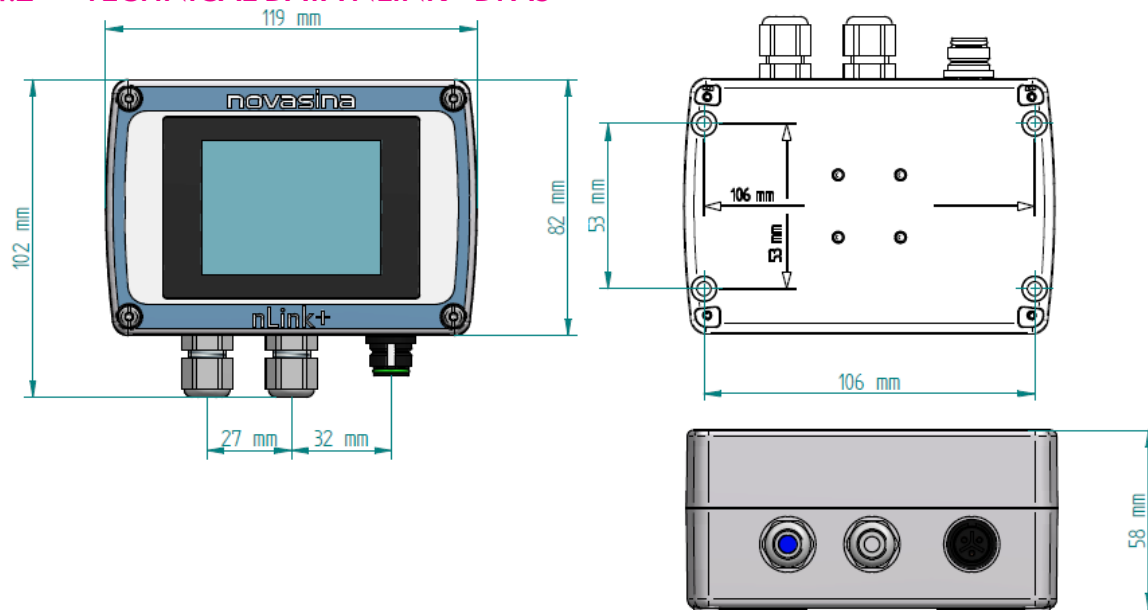

<b>Name</b>	nLink+ DI AS
<b>Art.-Nr.</b>	2602254
<b>Power supply</b>	24V DC, Permissible voltage range: 5 to 39V
<b>Power consumption</b>	<0.5W
<b>Display</b>	2.8 Zoll LCD Touch Display
<b>Status LED</b>	LED for power On, LED for nSens connected
<b>Output</b>	2 scalable analog outputs, current 0/4..20mA or voltage 0/2..10V  Accuracy <0.05% of span Linearity <0.05% of span Temperature effect 0.005% of span / °C  Load (I): min. 0Ω / max. 500Ω or (Uin-2V)/Imax Load resistance (U): min. 10 kΩ / max. ∞Ω
<b>Housing material</b>	PC/ABS
<b>Protection class</b>	IP54
<b>Soldering material</b>	lead free (RoHS compliant)
<b>Working temp.</b>	0 to 50°C
<b>Storage temperature</b>	-10 to 60°C (non-condensing)
<b>Compatibility</b>	Compatible with all nSens-HT V2.14 and later or nSens-dp
<b>CE-/EMC</b>	Safety: EN 61010-1:2020 EMC: IEC 61000-6-3:2020, EN 61000-6-3:2007+A1:2011 EN IEC 6100-6-3:2021 IEC 61000-6-2:2016, EN 61000-6-2:2019 IEC 61326-1:2012 / EN 61326-1:2013 IEC 61326-1:2020 / EN 61326-1:2021

### 4.3 TECHNICAL DATA NLINK+ EC AS

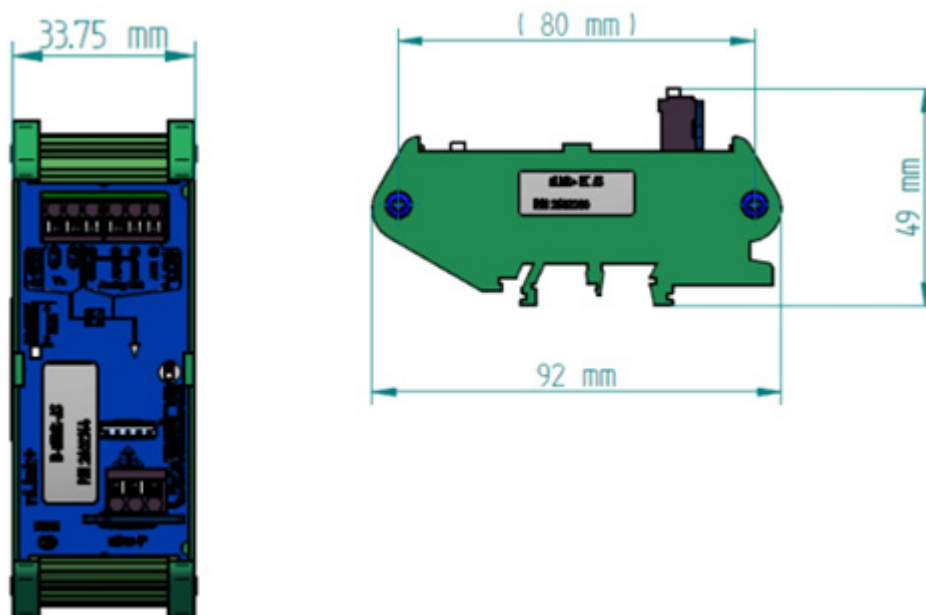

<b>Name</b>	nLink+ EC AS
<b>Art.-Nr.</b>	2602080
<b>Power supply</b>	24V DC, Permissible voltage range: 5 to 39V
<b>Power consumption</b>	<0.5W
<b>Status LED</b>	LED for power On, LED for nSens connected
<b>Output</b>	2 scalable analog outputs current 0/4..20mA or voltage 0/2..10V  Accuracy <0.05% of span Linearity <0.05% of span Temperature effect 0.005% of span / °C  Load (I): min. 0Ω / max. 500Ω or (Uin-2V)/Imax Load resistance (U): min. 10 kΩ / max. ∞Ω
<b>Housing material</b>	PA6.6 (UL94V0), mounting rail holder
<b>Protection class</b>	none, installation in protected cabinet required
<b>Soldering material</b>	lead free (RoHS compliant)
<b>Working temp.</b>	0 to 50°C
<b>Storage temperature</b>	-10 to 60°C (non-condensing)
<b>Compatibility</b>	Compatible with all nSens-HT V2.14 and later or nSens-dp
<b>CE-/EMC</b>	Safety: IEC 61010-1:2020 EMC: IEC 61000-6-2:2016, EN 61000-6-2:2019 IEC 61000-6-3:2020, EN 61000-6-3:2007+A1:2011

#### 4.4 TECHNICAL DATA NLINK+ IP AS DP

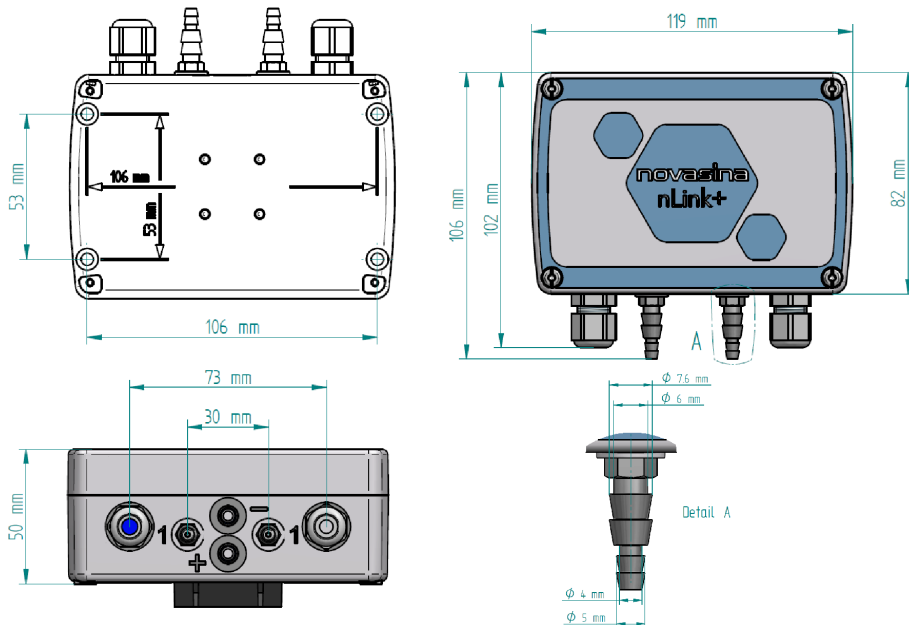

nLink+ IP	AS A / AS AA	AS B / AS BB	AS C / AS CC
Art.-Nr.	2602079 / 2602141	2602172 / 2602173	2602174 / 2602175
Measurement range	-25 to +25 Pa	-250 to +250 Pa	-5000 to +5000 Pa
Accuracy at 20°C (F.S.)	±0.15Pa	Range ±50Pa: ±0.20Pa Range ±1000Pa: ±0.25Pa Range ±250Pa: ±0.50Pa	±1.0% F.S
Temperature effect	Max. ±0.10Pa	Max. ±0.10Pa	Max. ±0.20Pa
Max. permissible overpressure	2 bar (burst pressure 4 bar)		0.1 bar (burst pressure 0.3 bar)
Flow rate	<200ul/min		None
Max. Resolution	0.1 Pa		
Long term stability	±0.05% FSS (typ)		
Ambient pressure dependency	Compensated with built in abs pressure sensor		
Ambient pressure: Range	700 – 1260 hPa / mBar		
Ambient pressure: Accuracy	±0.5 hPa		
Power supply	24V DC, Permissible voltage range: 5 to 39V		
Power consumption	<0.5W		
Status LED	LED for power On, LED for nSens connected		
Output	2 scalable analog outputs current 0/4..20mA or voltage 0/2..10V  Accuracy <0.05% of span Linearity <0.05% of span Temperature effect 0.005% of span / °C  Load (I): min. 0Ω / max. 500Ω or (Uin-2V)/Imax Load resistance (U): min. 10 kΩ / max. ∞Ω		
Housing material	PC/ABS		
Protection class	IP64		
Soldering material	lead free (RoHS compliant)		
Working temp.	0 to 50°C		
Storage temperature	-10 to 60°C (non-condensing)		
CE-/EMC	Safety: IEC 61010-1:2020 EMC: IEC 61000-6-2:2016, EN 61000-6-2:2019 IEC 61000-6-3:2020, EN 61000-6-3:2007+A1:2011		

## 4.5 TECHNICAL DATA NLINK+ DI AS DP

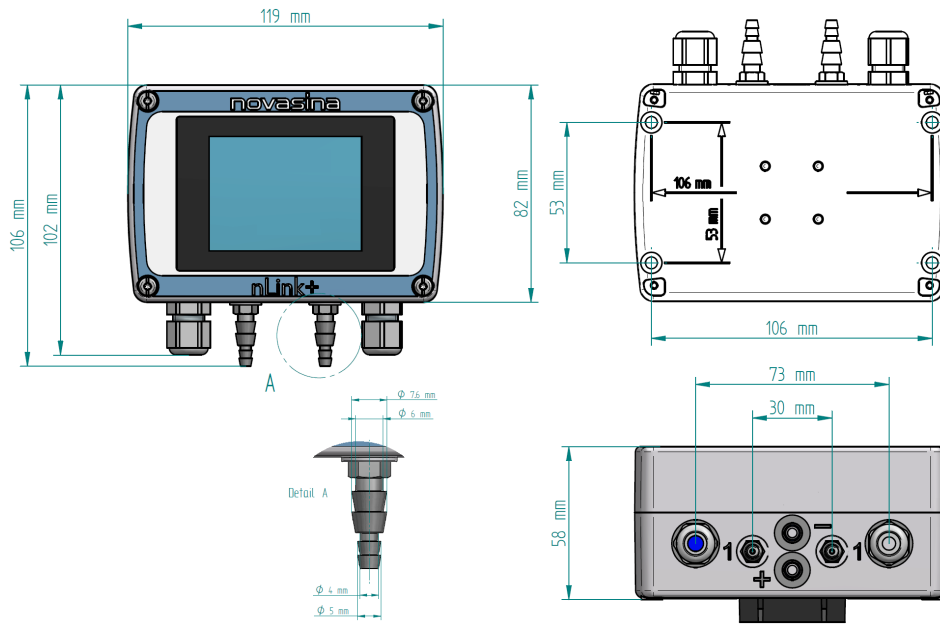

nLink+ DI	AS A / AS AA	AS B / AS BB	AS C / AS CC
Art.-Nr.	2602255 / 2602256	2602257 / 2602258	2602259 / 2602260
Measurement range	-25 to +25 Pa	-250 to +250 Pa	-5000 to +5000 Pa
Accuracy at 20°C (F.S.)	±0.15Pa	Range ±50Pa: ±0.20Pa Range ±1000Pa: ±0.25Pa Range ±250Pa: ±0.50Pa	±1.0% F.S
Temperature effect	Max. ±0.10Pa	Max. ±0.10Pa	Max. ±0.20Pa
Max. permissible overpressure	2 bar (burst pressure 4 bar)		0.1 bar (burst pressure 0.3 bar)
Flow rate	<200ul/min		None
Max. Resolution	0.1 Pa		
Long term stability	±0.05% FSS (typ)		
Ambient pressure dependency	Compensated with built in abs pressure sensor		
Ambient pressure: Range	700 – 1260 hPa / mBar		
Ambient pressure: Accuracy	±0.5 hPa		
Power supply	24V DC, Permissible voltage range: 5 to 39V		
Power consumption	<0.5W		
Display	2.8 Zoll LCD Touch Display		
Status LED	LED for power On, LED for nSens connected		
Output	2 scalable analog outputs current 0/4..20mA or voltage 0/2..10V  Accuracy <0.05% of span Linearity <0.05% of span Temperature effect 0.005% of span / °C  Load (I): min. 0Ω / max. 500Ω or (Uin-2V)/Imax Load resistance (U): min. 10 kΩ / max. ∞Ω		
Housing material	PC/ABS		
Protection class	IP54		
Soldering material	lead free (RoHS compliant)		
Working temp.	0 to 50°C		
Storage temperature	-10 to 60°C (non-condensing)		
CE-/EMC	Safety: EN 61010-1:2020 EMC: IEC 61000-6-3:2020, EN 61000-6-3:2007+A1:2011 EN IEC 6100-6-3:2021 IEC 61000-6-2:2016, EN 61000-6-2:2019 IEC 61326-1:2012 / EN 61326-1:2013 IEC 61326-1:2020 / EN 61326-1:2021		

#### 4.6 TECHNICAL DATA NLINK+ EC AS DP

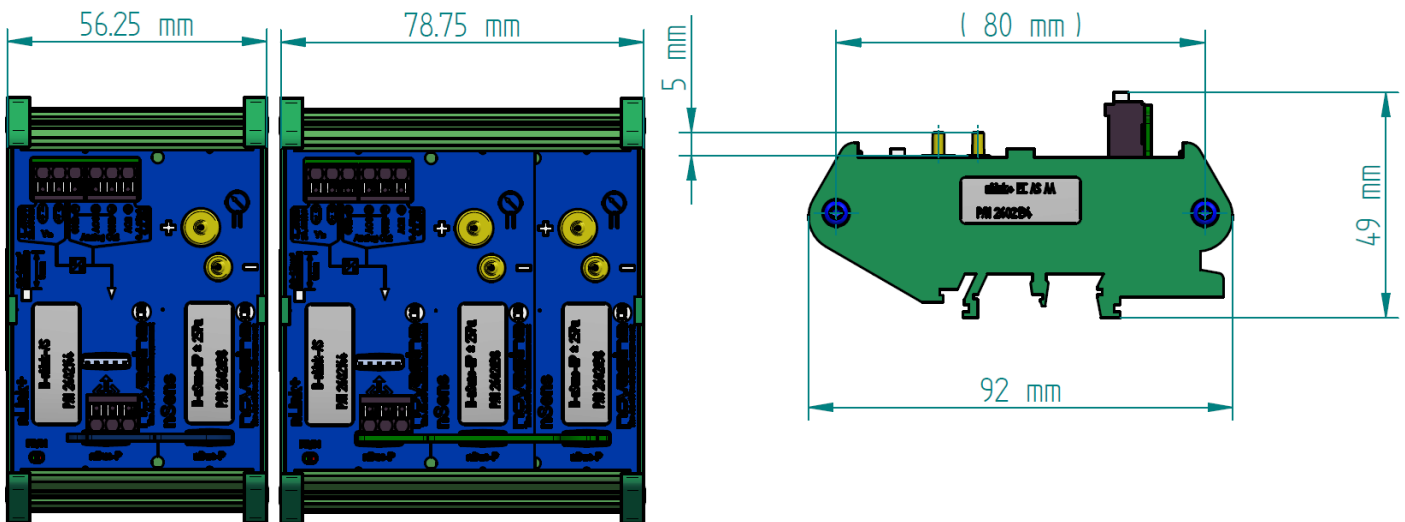

nLink+ EC	AS A / AS AA	AS B / AS BB	AS C / AS CC
Art.-Nr.	2602044 / 2602134	2602203 / 2602204	2602205 / 2602206
Measurement range	-25 to +25 Pa	-250 to +250 Pa	-5000 to +5000 Pa
Accuracy at 20°C (F.S.)	±0.15Pa	Range ±50Pa: ±0.20Pa Range ±1000Pa: ±0.25Pa Range ±250Pa: ±0.50Pa	±1.0% F.S
Temperature effect	Max. ±0.10Pa	Max. ±0.10Pa	Max. ±0.20Pa
Max. permissible overpressure	2 bar (burst pressure 4 bar)		0.1 bar (burst pressure 0.3 bar)
Flow rate	<200ul/min		None
Max. Resolution	0.1 Pa		
Long term stability	±0.05% FSS (typ)		
Ambient pressure dependency	Compensated with built in abs pressure sensor		
Ambient pressure: Range	700 – 1260 hPa / mBar		
Ambient pressure: Accuracy	±0.5 hPa		
Power supply	24V DC, Permissible voltage range: 5 to 39V		
Power consumption	<0.5W		
Status LED	LED for power On, LED for nSens connected		
Output	2 scalable analog outputs current 0/4..20mA or voltage 0/2..10V  Accuracy <0.05% of span Linearity <0.05% of span Temperature effect 0.005% of span / °C  Load (I): min. 0Ω / max. 500Ω or (Uin-2V)/Imax Load resistance (U): min. 10 kΩ / max. ∞Ω		
Housing material	PA6.6 (UL94V0), mounting rail holder		
Protection class	none, installation in protected cabinet required		
Soldering material	lead free (RoHS compliant)		
Working temp.	0 to 50°C		
Storage temperature	-10 to 60°C (non-condensing)		
CE-/EMC	Safety: IEC 61010-1:2020 EMC: IEC 61000-6-2:2016, EN 61000-6-2:2019 IEC 61000-6-3:2020, EN 61000-6-3:2007+A1:2011		

### 4.7 WIRING DIAGRAM

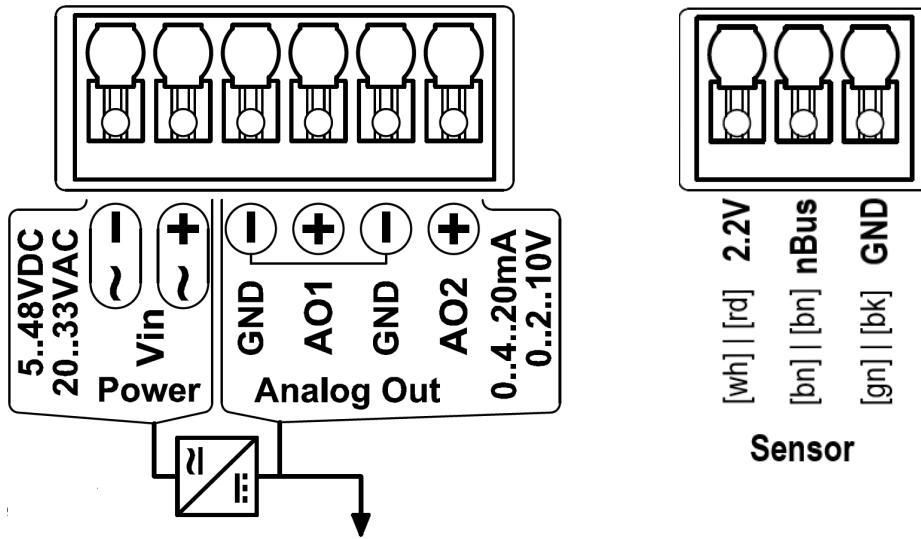

### 4.8 ELECTRICAL INSTALLATION

	Wire specification
Clamping range	0.13 - 1.5mm <sup>2</sup> (Push-in Spring clip)
Wires	w. plastic collar ferrule DIN 46228/4: 0,25 - 0.75 mm <sup>2</sup>
	w. wire end ferrule DIN 46228/1: 0,25 - 1.50 mm <sup>2</sup>
	Solid, min. H05(07) V-U 0.2 - 1.50 mm <sup>2</sup>
	Wire connection cross section AWG28 - 14

**Remark:**

Cable specifications depend on the installation and have to be defined by the designer or installer. Heavy machinery and other instrumentation should not share the same power supply wiring. Use noise filters and surge protectors if required.

For EMC protection it is recommended to take the following measures:

- Wires emitting interference must be separated from measurement and analysis units
- Parallel guidance of measurement cables and electrical power cables must be avoided, use different channels with separation (see European Standard EN50170 for detailed information)

**Remark:**

If more than 1 probe is connected, the single wires can be fixed in parallel in the same screw terminal.

### 4.9 TUBE CONNECTIONS

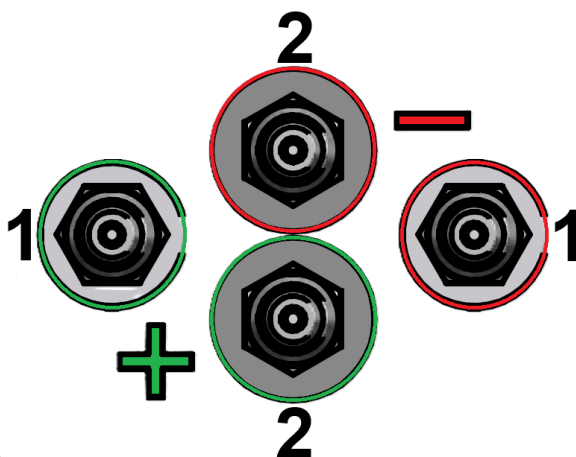

In order to get a positive value, connect the higher pressure on the + inlet.

The tube connections for sensor 1 and sensor 2 need to be connected as described.

## 5. INITIAL OPERATION

Before initial operation the power supply wiring and analogue output configuration should be checked (see wiring diagram).

### Important remark:

The power supply fuse protection has to be verified according to the local regulation. Voltages over 39VDC/27.6VAC result in a severe damage of the device!

### 5.1 DISPLAY FUNCTIONS

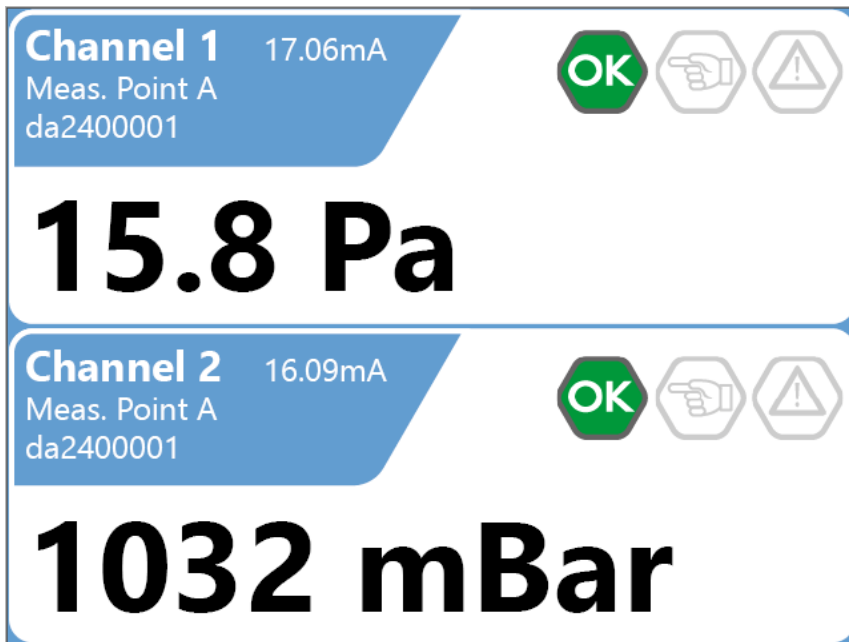

To access the menu, tap on the display. Only settings for the display backlighting can be made in the menu and no configurations.



Brightness after the display is woken up by tapping  
Can be set from 1 to 9

Brightness after automatic dimming  
Can be set from 1 to 9

Time until automatic dimming

### Important note:

The lifetime of the display depends on the set brightness and time.  
The higher the brightness and the longer the time is set, the shorter the lifetime of the display!

## 6. WINDOWS PC SOFTWARE INSTALLATION

The software «nSoft-ACT-T» is a requirement for the configuration (signal outputs, sensor parameters etc). The software must be installed on a Windows PC with administrator rights and following minimum requirements:

Supported operating systems:

- Windows XP with SP3 or higher (32+64bit)
- Administrator-rights

Hardware:

- CPU: mind. 1 GHz
- USB- connection
- min. 512 MB free memory
- min. 4 GB free hardware memory
- Software Adobe Acrobat Reader

The software can be obtained on the website [www.novasina.ch](http://www.novasina.ch) or send an email to [sales@novasina.ch](mailto:sales@novasina.ch).

Software is license free (Freeware), the special USB configuration cable with adapter is necessary (see accessories)

## 7. CONFIGURATION WITH NSOFT-ACT-T

Connect the USB cable on the PC and the nLink+.  
Open the software by clicking on the Icon after installation.



The nLink+ does not require additional power supply. The USB connector is sufficient for configuration and sensor connection.

Analog signals / outputs are only active with the additional power supply.

### 7.1 STARTUP

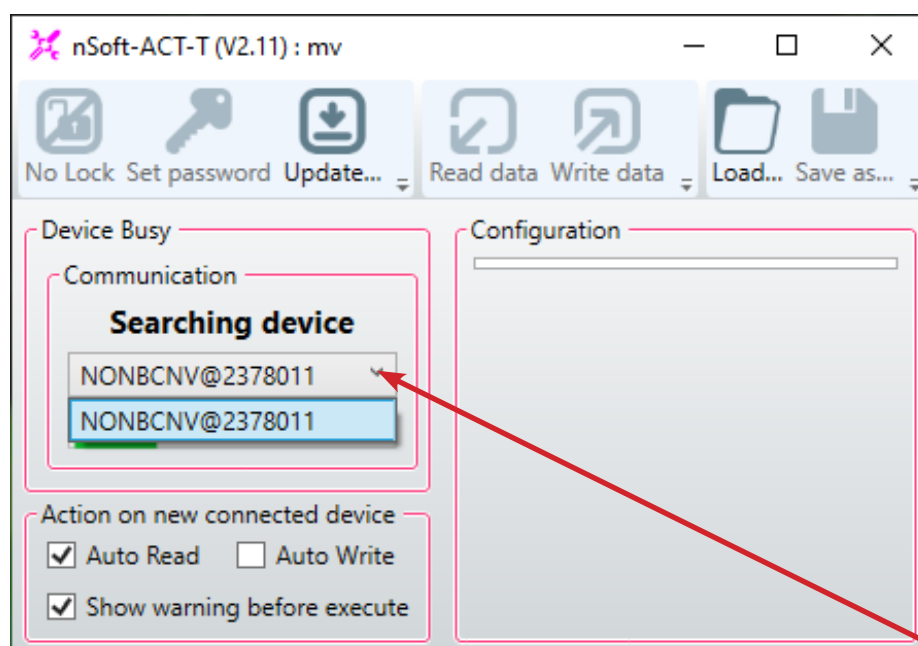

Connect configuration cable on the nLink+ and your PC. Choose the adapter in the dropdown menu.

## 7.2 MAIN SCREEN

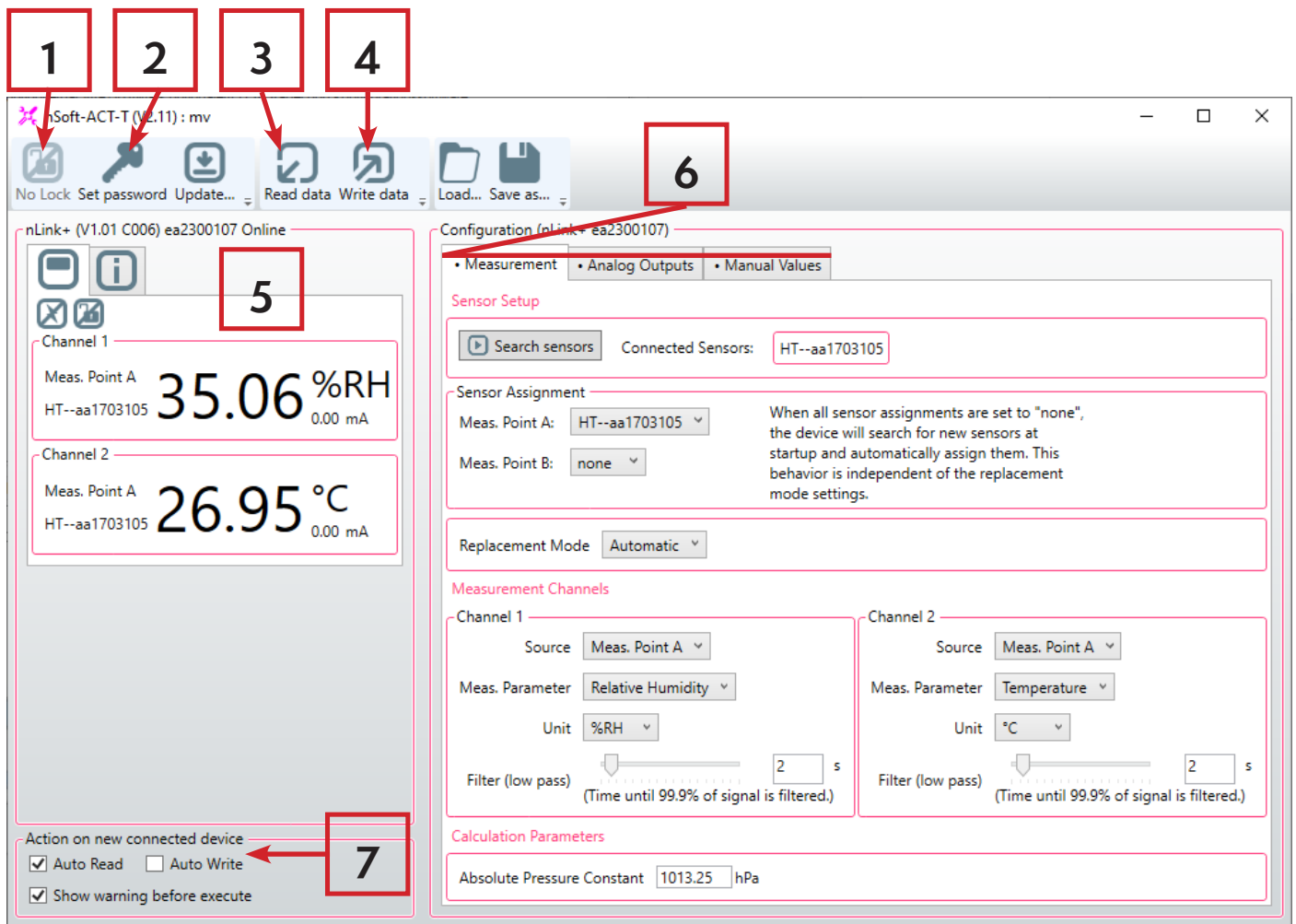

The screenshot shows the main interface of the hSoft-ACT-T software. At the top, there are four numbered callouts (1-4) pointing to icons for 'No Lock', 'Set password', 'Update...', and 'Read data'/'Write data'. Below these is a toolbar with icons for 'Load...' and 'Save as...'. On the left, a panel displays real-time data for two channels: Channel 1 (35.06 %RH) and Channel 2 (26.95 °C). A callout (5) points to this data panel. On the right, a 'Configuration' panel is shown with callout (6) pointing to its title bar. This panel includes sections for 'Sensor Setup', 'Sensor Assignment', 'Replacement Mode', 'Measurement Channels', and 'Calculation Parameters'. A callout (7) points to the 'Action on new connected device' section at the bottom left, which contains checkboxes for 'Auto Read', 'Auto Write', and 'Show warning before execute'.

- 1: Activate password protection, requires a password set (2)
- 2: Set Password: the password is stored directly on the transmitter.
- 3: Read Data: Read configuration from the nLink+
- 4: Write Data: Store the configuration on the nLink+
- 5: Details from the nLink+, such as serial numbers, measured values in real time etc.
- 6: Configuration-Register:
  - Measurement: Search connected sensors, choose channels and parameters
  - Analog Outputs: Configuration for analog outputs, low/high range etc
  - Manual Values: Set manual values for simulation and look control.
- 7: Action on new device.
  - Auto Read: Transmitter configuration is automatically transferred to the software and displayed. Prepared configuration in the software is overwritten.
  - Auto Write: The configuration prepared on the software is automatically written to the nLink+. Ideal to quickly configure multiple nLink+ with the same settings.
  - Show warning before execute: If active a warning message will appear before read or write. Deactivate if necessary.

### 7.3 CONFIGURATION PROCEDURE

- Choose the adapter if the software does not automatically recognize
- Configure sensor (search sensor), measuring point and channels (6)
- Configure analog output settings (6, register analog out)
- After configuration activate «Write Data» (4) to store the settings on the transmitter.

### 7.4 UPDATE REQUIRED

If a firmware version on the nlink+ is not compatible with the installed nSoft-ACT-T this message «Update required» is shown.

Contact your local support for the newest firmware file and update instructions.

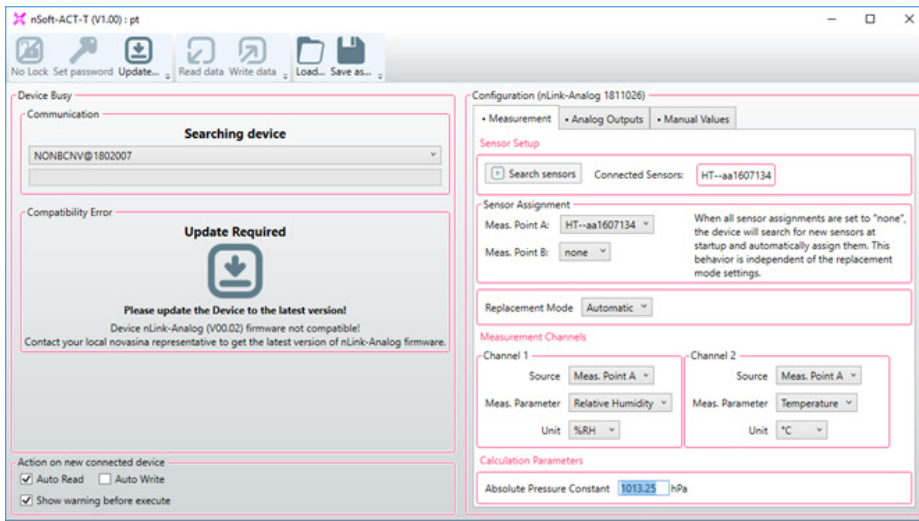

### 7.5 NEW CONFIGURATION

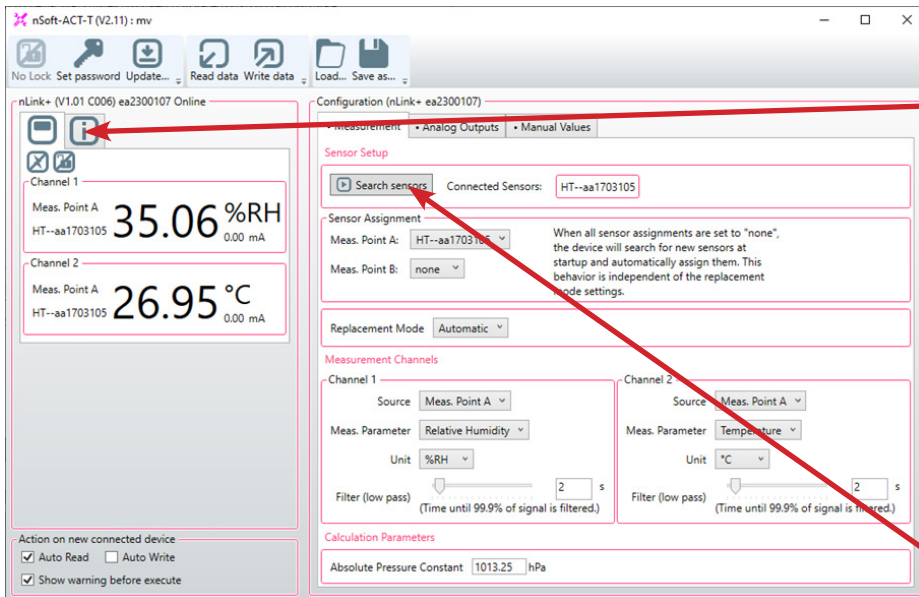

nlink+ is recognized. Register «i» displays additional information about the transmitter.

Click on «Search Sensor» Connected nSens probe will be recognized and displayed with the serial number.

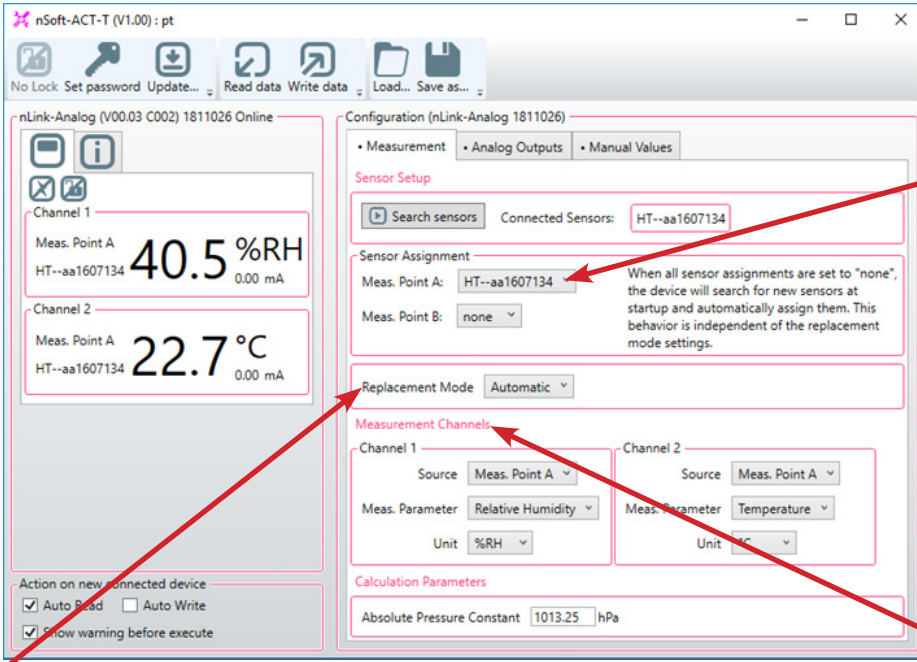

The identified nSens must now be assigned to measuring points. If one nSens is connected it is automatically assigned to measuring point A.

« Measurement Channel» 1 and 2 correspond to analog out 1 and 2. Choose parameter and unit (depending on the type of nSens).

« Replacement Mode»:

Automatic (default): If the nSens is replaced the nLink+ recognizes the different serial number and replace the removed nSens with the new nSens to the same measuring point. Configuration remains.

Manual: A different nSens has to be configured with this software again.

## 7.6 CONFIGURATION ANALOG OUTPUTS

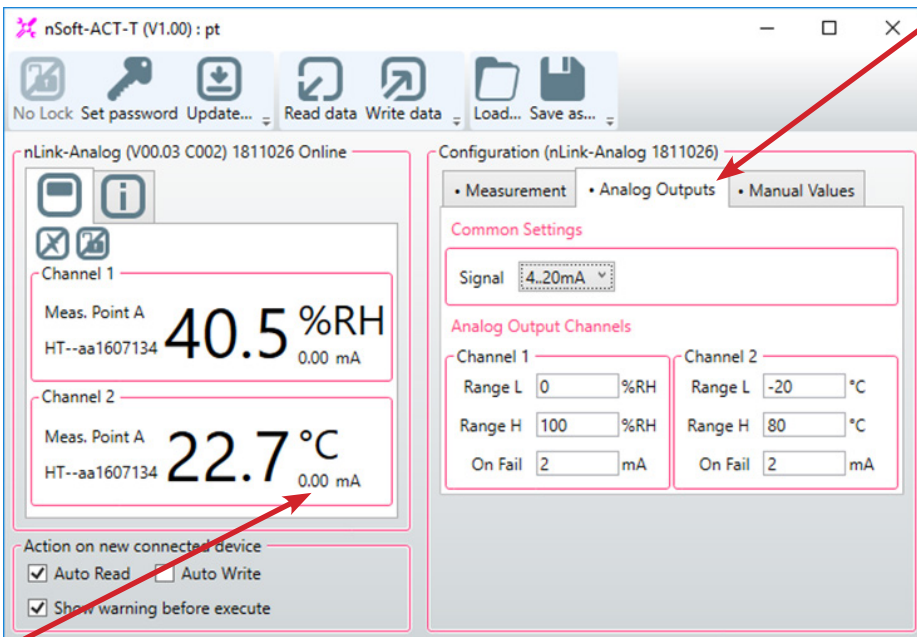

Register «Analog Outputs». Assign Signals (Loop mA oder V) and Range (Range low / Range high) according the specification from the automation system.

On Fail: In case an error is detected (e.g. nSens disconnected) this output is active. If power supply is interrupted signal output is zero.

Store configuration with Write Data:

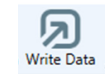

Actual analog value on the output for each channel. Only active with additional power supply.

The configuration remains as long as no other nLink+ is connected and Read Data is activated.

Choose "Auto Write" and connect another transmitter. The prepared settings will now be stored on the transmitter automatically.

## 7.7 MANUAL VALUES

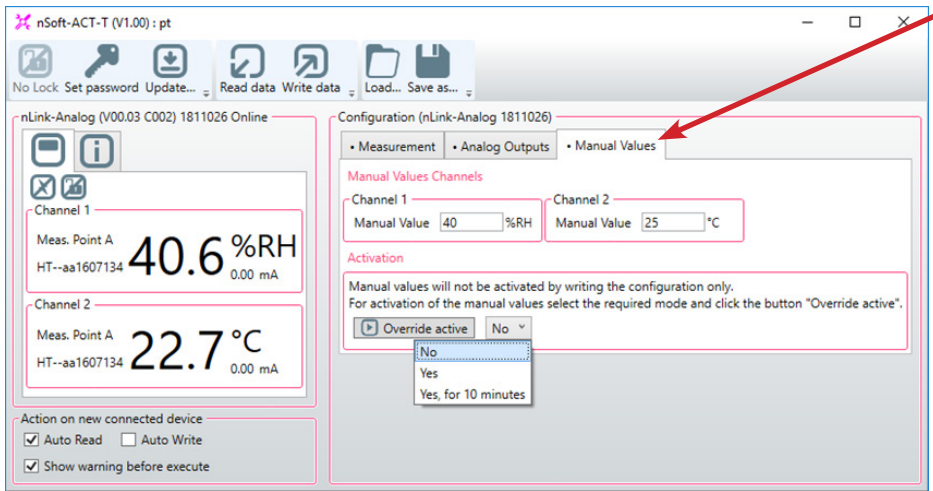

Program fixed values for Simulation and loop checks. Choose Override mode and "Write Data" for activation. As long as manual values are active the sensor values are not displayed.

**Beware:** Deactivate override after completing the checks to receive real time data from the nSens again.

## 7.8 SENSOR CALIBRATION

Only visible if a dP sensor is connected

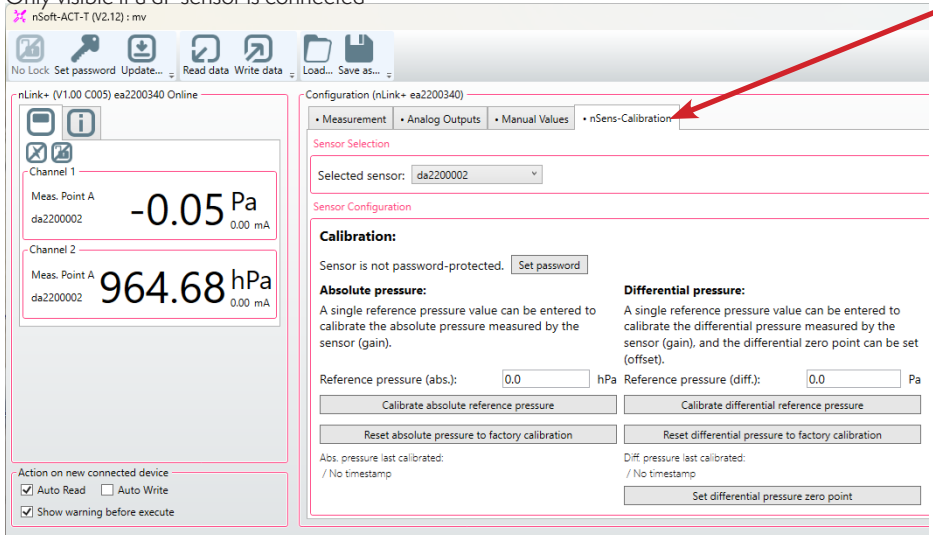

Calibration menu to adjust sensors or to perform a zero point calibration. The sensor to be adjusted must first be selected via the dropdown menu.

## 8. CALIBRATION / VERIFICATION OF MEASURING VALUES

For humidity calibration and verification Novasina humidity standards are recommended. These humidity generators are easy to use and reusable multiple times.



For the verification of the whole measurement range Novasina offers a set with 5 SAL-SC including carrying case and probe adapter rings. For an optimal calibration and/or verification the room temperature should be between 15...30°C and should not vary more than +/-0,2°C. In order to allow the standards to generate an accurate and stable air humidity the SAL-SC must be well sealed around the probe.

For this purpose an adapter with O-ring can be used, which is put inside the SAL-SC hole and then put over the probe. The standards should be adapted to the climatic ambient conditions approx. 1 hour before they are used.

If handled properly the SAL-SC generate very stable and accurate relative humidity and can be used as an alternative to humidity generators.



### 8.1 SENSOR CABLES AND CONFIGURATION SET

nSens cable with end sleeves	nSens cable extensions	Configuration cable: nlink-USB & CA3
Connects nSens with nlink+	Extension cable between any connector and nSens.	Configuration cable for nLink+ to Windows PC. Software available for download
		
2601080 nSens-cable 5m 2601079 nSens-cable 10m 2601078 nSens-cable 30m 2601225 nSens-cable 60m 2601226 nSens-cable 100m	2601201 nSens Extension 2m 2601136 nSens Extension 5m 2601986 nSens Extension 10m 2601987 nSens Extension 30m	2601818 nlink-USB-CA3 (complete set)

## 8.2 ACCESSORIES NSENS HT



Art. No. 1110885 - SAL-SC 11  
 Art. No. 1110855 - SAL-SC 33  
 Art. No. 1110857 - SAL-SC 53  
 Art. No. 1110859 - SAL-SC 75  
 Art. No. 1110896 - SAL-SC 90

### Sensor-Checks SAL-SC

(humidity standards)

Reusable humidity standards based on saturated salt solutions in plastic cylinders with moisture permeable membranes. Each salt is delivered in a well-sealed box. Sensor Checks SC are obtainable for the following values (at 25°C):

11.3 % rh	75.3 % rh
32.8 % rh	90.1 % rh
52.9 % rh	

Important: please consult the operation manual of your instrument to see which points can be calibrated.  
 Other SAL-SC can be used for verification.

### Humidity values in the temperature range 15°...30°C:

11.3 ..... 11.3% rh / 15...30°C  
 33.3 ..... 32.4% rh / 15...30°C  
 55.9 ..... 51.4% rh / 15...30°C  
 75.6 ..... 75.1% rh / 15...30°C  
 90.9 ..... 89.9% rh / 15...30°C

The precision corresponds to the Greenspan Report 1977 typically +/- 0.3 % rh

**Weight:** 90 g



Art. No. 1117847  
 SAL-SC Sensor Check Set  
 Art. No. 1117841  
 Empty case for SAL-SC

### Set with 5 Humidity Generators SAL-SC

Reusable humidity standards SAL-SC in a case delivered incl. the needed adapters for Novasina probes and factory calibration certificates.

Case set contains:

- SAL-SC 11
- SAL-SC 33
- SAL-SC 53
- SAL-SC 75
- SAL-SC 90
- Factory calibration certificates of SAL-SC
- 1 adapters for Novasina probes

### Humidity values in the temperature range 15°... 30°C:

11.3 ..... 11.3% rh / 15...30°C  
 33.3 ..... 32.4% rh / 15...30°C  
 55.9 ..... 51.4% rh / 15...30°C  
 75.6 ..... 75.1% rh / 15...30°C  
 90.9 ..... 89.9% rh / 15...30°C

The precision corresponds to the Greenspan Report 1977 typically +/- 0.3 % rh

**Weight:** 900 g

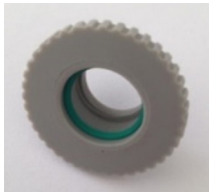

Art. No. 2601143 Adapter  
 SAL-SC for nSens probes

### Adapter SAL-SC for nSens probes

Plastic adapter for humidity standards. Used for diameter reduction and radial sealing around the nSens probe with diameter 13mm.

With integrated green coloured rubber sealing ring

### Dimension:

Out.diameter 30 mm  
 Inner diameter 13 mm

**Weight:** 5 g

### Material:

Thermoplastic resin



Art. No. 1111302  
 Styrofoam box

### Thermal insulation styrofoam box

A styrofoam box providing optimal insulation and temperature stabilisation of a SAL-SC check during the calibration procedure. Consisting of two half-covers for simple temporary mounting.

### Dimension:

100 x 65 x 50 mm

**Weight:** 10 g

### Material:

thermal insulating  
 styrofoam PPE