



Transmitter with ModbusRTU output for the continuous measurement of differential pressure in a IP64 case.

Can be ordered as a variant with 1 or 2 dP sensors.

Bidirectional differential pressure sensors based on dynamic (massflow) measurement with absolute pressure sensor included.

Configuration with USB cable for Windows PC.

Configuration possible without external power supply.

Art.-Nr.:

2602225
2602226

Product-name:

nLink+ IP MR A 1*dp sensor ± 25 Pa
nLink+ IP MR AA 2*dp sensor ± 25 Pa

Technical data:

Measurement Range	-25 to +25 Pascal
Accuracy at 20°C	± 0.15 Pa
Temperature effect	Max. ± 0.10 Pa
Max. Resolution	0.1 Pa
Long term stability	$\pm 0.05\%$ FSS (typ)
Flow rate	<200ul/min
Ambient pressure dependency	Compensated with built in abs pressure sensor
Ambient pressure: Range	700 – 1260 hPa / mBar
Ambient pressure: Accuracy	± 0.5 hPa
Max. permissible overpressure	2 bar (burst pressure 4 bar)
Power supply	24V DC, Permissible voltage range: 5 to 39V
Power consumption	<0.5W
Display	none
Status LED	LED for power On, LED for nSens connected
Output	ModbusRTU (all climate values and diagnostic information as described in the Modbusregister)
Housing material	PC/ABS
Protection class	IP64
Soldering material	lead free (RoHS compliant)
Working temperature	0 to 50°C
Storage temperature	-10 to 60°C (non-condensing)
CE-/EMC	Safety: EN 61010-1:2020 EMC: IEC 61000-6-2:2016, EN 61000-6-2:2019 IEC 61000-6-3:2020, EN 61000-6-3:2007+A1:2011

Electrical installation:

Clamping range	0.13 - 1.5mm ² (Push-in Spring clip)	
Wires	w. plastic collar ferrule DIN 46228/4:	0,25 - 0.75 mm ²
	w. wire end ferrule DIN 46228/1:	0,25 - 1.50 mm ²
	Solid, min. H05(07) V-U	0.2 - 1.50 mm ²
	Wire connection cross section AWG28 - 14	

Cable specifications depend on the installation and have to be defined by the designer or installer. Heavy machinery and other instrumentation should not share the same power supply wiring. Use noise filters and surge protectors if required.

For EMC protection it is recommended to take the following measures:

- Wires emitting interference must be separated from measurement and analysis units
- Parallel guidance of measurement cables and electrical power cables must be avoided, use different channels with separation (see European Standard EN50170 for detailed information)

Dimension & Schematics:

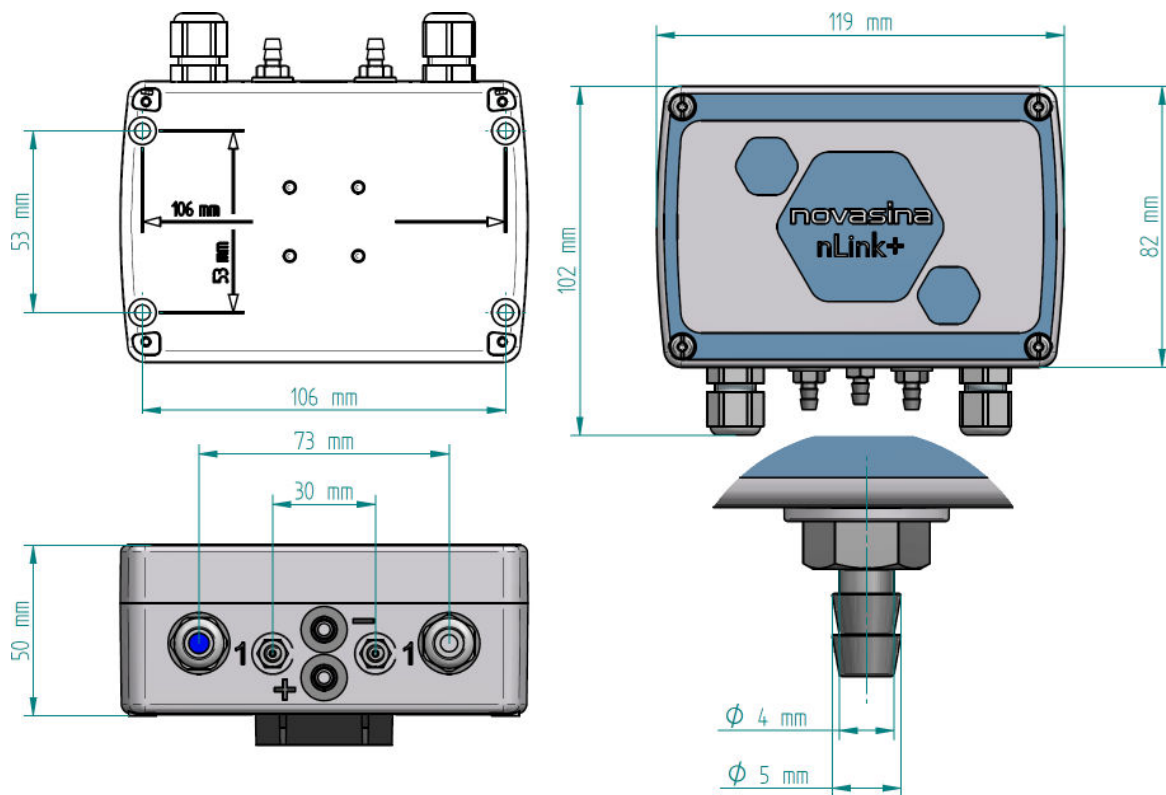

More information & accessoires

[Link to Website>](#)



Technical data subject to change without prior notice